

## DIMENSIONS

All dimensions are approximate. Dimensions may vary with bucket and tire choice. Refer to operating specifications.

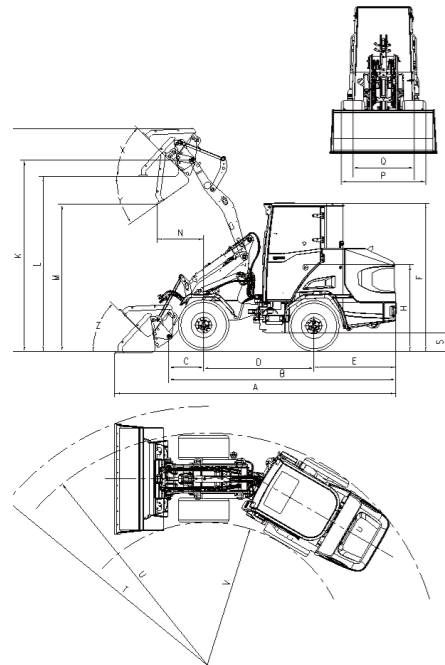

NO.	DESCRIPTION	UNIT	STD
A	Total Length	mm	4470
B	Length Without Bucket	mm	3570
C	Front Overhang	mm	545
D	Wheelbase	mm	1730
E	Rear Overhang	mm	1295
F	Height	mm	2340
H	Seat Height	mm	1330
J	Overall Working Height	mm	3660
K	Maximum Lift Height at Hinge Pin	mm	3004
L	Bucket Level Height	mm	2680
M	Dump Height	mm	2200
N	Dump Reach	mm	235
O	Digging Depth	mm	80
P	Overall Width	mm	1415
Q	Track Width (Wheel Track)	mm	1045
S	Ground Clearance	mm	250
T	Bucket Outside Turning Radius	mm	3300
U	Outer Turning Radius (Wheel Outside)	mm	2500
V	Inner Turning Radius (Wheel Inside)	mm	1085
W	Steering Angle	°	42
X	Bucket Tilt Angle	°	42
Y	Dump Angle	°	35
Z	Bucket Rollback Angle	°	51

## TECHNICAL PARAMETERS

BASIC	Bucket Capacity	0.45m <sup>3</sup>
	Rated Payload	800kg
	Tipping Load(Bucket)	Fully articulated ≥1600kg
	Tipping Load(Fork)	Fully articulated ≥1300kg
	Operating Weight	2900±100kg
	Traction Force	19KN
	Breakout Force	22KN
	L×W×H	4470×1415×2340
ENGINE	Manufacturer	Kubota
	Model	D1703
	Rated Power	18.5/2200kw/rpm
	Rated Torque	96N.m/900-2100rpm
	Displacement (L)	1.8
DRIVE TRAIN	Transmission Type	Hydrostatic transmission
	Shift Type	Electronic powershift control
	Pump Type	Piston pump
	System Pressure	35Mpa
	Tire	31×15.5-15
	Travel speed-Forward	8/20km/h
Travel speed-Reverse	8/20km/h	
BRAKE SYSTEM	Service Brake	Flexible shaft drum brake
	Parking Brake	Hydraulic drum brake
STEERING SYSTEM	Type	Hydraulic hinge, swing steering
	System Pressure	35MPa
HYDRAULIC SYSTEM	Type	Gear pump
	Working Flow	50L/min
	System Pressure	18.5MPa
	Cycle Time (Sec)	9.1S
ELECTRIC SYSTEM	System Voltage	12V
	Battery	12V, 100Ah
SERVICE REFILL CAPACITY	Fuel Tank	50L
	Hydraulic Tank	40L

## CONFIGURATION

Kubota Engine (EPA Tier 4F/ EU Stage V)
Hydrostatic Transmission
Piston Pump & Motor
ROPS&FOPS Cabin
Air Conditioner
Multifunctional LCD screen
100% differential lock
LED Work Light

## OPTIONAL

Customized Bucket
Customized Forks
Customized Clamp
High Dump Boom

# Lonking 龙工

# CDM908A WHEEL LOADER



The following blank can be used for notes or comments.

**For more information on Lonking products,  
Please contact our local agent:**

Lonking, Lonking CDM Series and their respective logos, as well as corporate identity in this leaflet are trademarks of Lonking Holdings Ltd., and may not be used without written permission.  
2025/08

Specifications and design are subject to change without prior notice.  
Machines shown may not include optional accessories.

Lonking (FUJIAN) INTERNATIONAL TRADE CO., LTD.

**Lonking Holdings Limited**

Add: 26 Minyi Road, Xinqiao, Songjiang Industrial Zone, Shanghai

Tel: +86-21-3760 2242 E-mail: export@lonking.cn

http://www.lonkinggroup.com

■ RATED POWER:	18.5kW/2200rpm
■ BUCKET CAPACITY:	0.45m <sup>3</sup>
■ RATED PAYLOAD:	800kg
■ OPERATING WEIGHT:	2900±100kg