

## DIMENSIONS

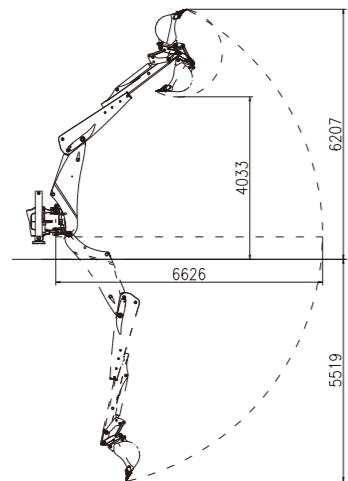
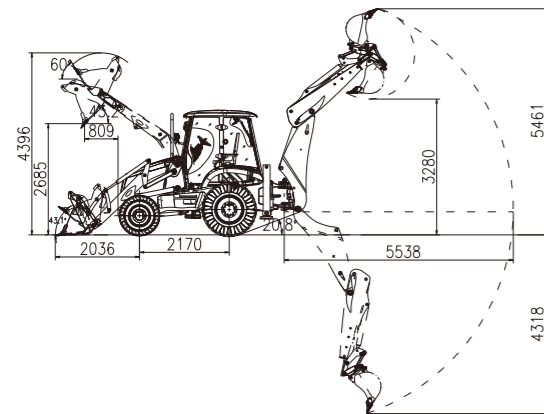
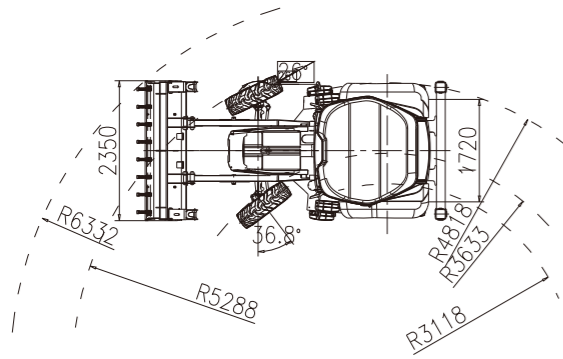
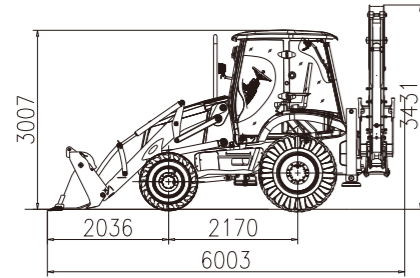

## TECHNICAL PARAMETERS

Basic	Specification
Operating weight	8300 kg
Standard loading bucket capacity	1.0 m <sup>3</sup>
Standard excavating bucket capacity	0.2 m <sup>3</sup>
Max. tractive force	74 kN
Max. digging force-loader	61 kN
Max. breakout force-loader	61 kN
Max. arm digging force-excavator	38 kN
Max. bucket digging force-excavator	61 kN
<b>Engine</b>	
Brand	Weichai
Model	WP4G95E221
Type	Water cooling, Four cylinder, four
Rated Power(SAE J1349)	70kw*2200rpm
Max. Torque	380Nm
Displacement	4.5L
<b>Transmission</b>	
Brand, model and type	Carraro
Gears forward	4
Gears reverse	4
Max. speed forward	36.4 km/h
Max. speed reverse	21.3 km/h
Service brake type	Wet brake
Parking brake type	Caliper disc brake
<b>Front axle</b>	
Brand and type	Carraro, Steering axle
Steering angle	38°
<b>Rear axle</b>	
Brand and type	Carraro , Wet axle
<b>Tyres</b>	
Front	14-17.5-14PR
Rear	19.5L-24-12PR
Front tyre pressure	0.55±0.03 Mpa
Rear tyre pressure	0.23±0.03 Mpa
<b>Hydraulics</b>	
Type	Load sensitive hydraulic steering
Max. flow	165 L/min
Max. pressure	25.1 Mpa
<b>Service fill capacities</b>	
Fuel	155 L
Hydraulic oil	117 L
Engine	10 L
Transmission	19.5 L
Anti freeze	18.5 L
Front axle	9.1 L
Rear axle	17.5 L

# LONKING 龙工

Efficiency Rules the Future

# 83C BACKHOE LOADER

Weichai direct injection engine.  
Carraro transmission and axles.

The excavating side with side shift frame and swing boom.  
Six sided panoramic cab, Rotating seat integrated pilot control.



The following blank can be used for notes or comments

For more information on Lonking products, Please contact our local agent;

**LONKING (FU JIAN) INTERNATIONAL TRADE CO., LTD.**  
Add: 26 Minyi Road, Xinqiao, Songjiang Industrial Zone, Shanghai  
E-mail: export@lonking.cn <http://www.lonkinggroup.com>  
Tel: +86-21-3760 2242

- RATED POWER: 70kW/2200rpm
- MAX. FORWARD SPEED: 36.4km/h
- OPERATING WEIGHT: 8300kg

Specifications and design are subject to change without prior notice.  
Machines shown may not include optional accessories.